



Description

DF galvanised side corners are used to join DF20, 30 and 40 channels and thus create an end cover for connecting two rectangular ducts. The side corners can be made of acid-proof material or aluminium.

Example identification
 Product code: DF-20-C
 type _____
 material _____

Dimensions

Side Corner DF-C-20

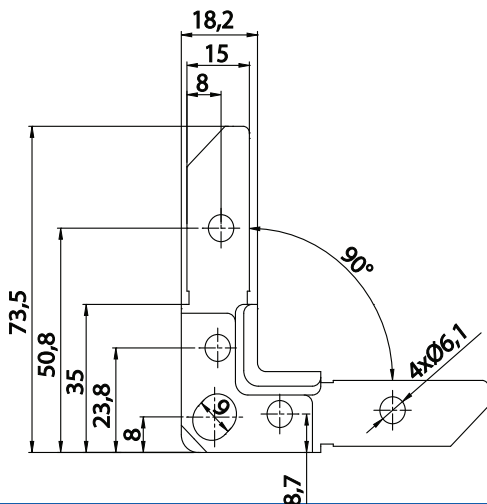

Side Corner DF-C-20K

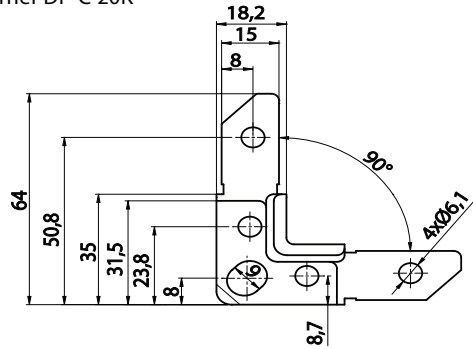

Side Corner DF-C-20L

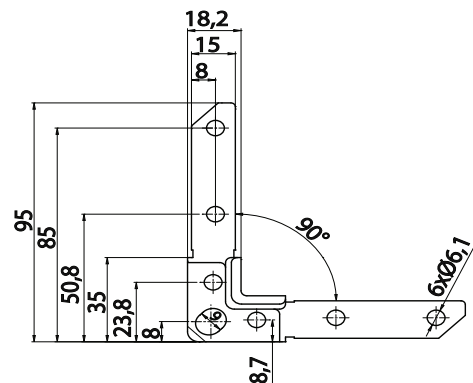

Side Corner DF-C-30

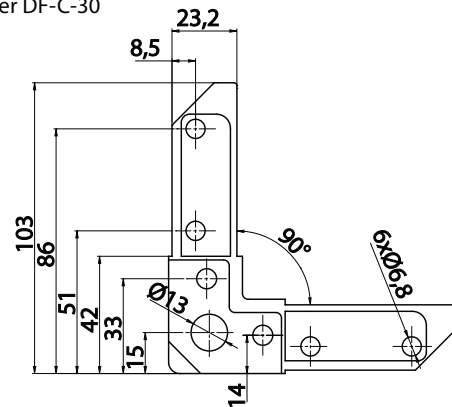

Side Corner DF-C-40

